



CE MODELS | SJIII 4620 SJIII 4626 SJIII 4632



CONVENTIONAL SERIES DC Electric SCISSOR LIFTS

The Conventional Series DC Electric Scissor Lifts offer high capacity and large platform areas, making them suitable for any on-slab application. Featuring variable speed rear wheel hydraulic drive, the Conventional Series offers working heights up to 11,9 m and 25% gradeability.

Boasting an industry leading 590 kg capacity, the SJIII 4620 also features a stowed height of only 2,0 m for easy transport and access through some low overhead doors.

A standard 1,2 m roll out extension deck can be secured in multiple positions, and all three models can be driven at full height. Consistent with Skyjack's robust and reliable design features, the Conventional Series DC Electric Scissor Lifts utilize Skyjack's standard colour coded and numbered wiring system with analog based controls.



CONVENTIONAL SERIES

DC Electric Scissor Lifts

Specifications	SJIII 4620	SJIII 4626	SJIII 4632
A Work Height	8,1 m	9,9 m	11,8 m
B Raised Platform Height	6,1 m	7,9 m	9,8 m
C Lowered Platform Height	1,0 m	1,1 m	1,2 m
D Overall Width	1,2 m	1,2 m	1,2 m
E Overall Length	2,3 m	2,3 m	2,3 m
F Stowed Height (Rails Up)	2,0 m	2,1 m	2,2 m
G Stowed Height (Rails Down)	1,6 m	1,8 m	1,9 m
H Platform Width (Inside Dimension)	1,1 m	1,1 m	1,1 m
I Platform Length (Inside Dimension)	2,1 m	2,1 m	2,1 m
Extension Deck (Roll Out)	1,2 m	1,2 m	1,2 m
Ground Clearance (Stowed)	8,9 cm	8,9 cm	8,9 cm
Ground Clearance (raised)	1,9 cm	1,9 cm	1,9 cm
Wheelbase	1,8 m	1,8 m	1,8 m
Weight	1860 kg	2132 kg	2302 kg
Gradeability	25%	25%	25%
Turning Radius (Inside)	1,2 m	1,2 m	1,2 m
Turning Radius (Outside)	2,4 m	2,4 m	2,4 m
Lift Time (With Rated Load)	32 sec	54 sec	59 sec
Drive Speed (Stowed)	3,2 km/h	3,2 km/h	3,2 km/h
Drive Speed (Raised)	1 km/h	1 km/h	1 km/h
Maximum Drive Height	Full Height	Full Height	Full Height
Capacity (Overall)	590 kg	454 kg	318 kg
Maximum # of Persons	3	3	2

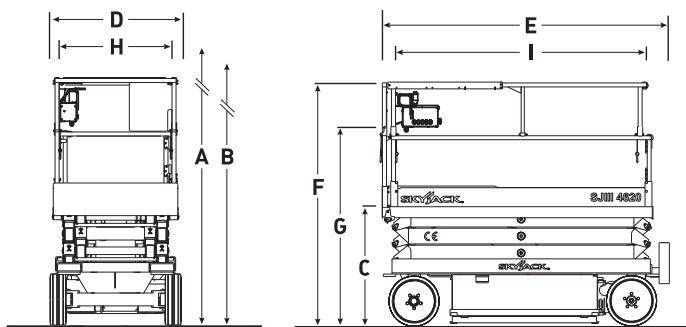

STANDARD FEATURES

- Drivable at full height
- Variable speed, rear two wheel hydraulic drive
- Dual holding brakes
- Proportional controls for drive & lift functions
- 1,2 m roll out extension deck
- 24V DC power source
- Low voltage battery protection
- Analog control system
- Colour coded and numbered wiring system
- 25% gradeability
- Solid rubber, non-marking tyres
- Pothole protection system
- Wiring for AC outlet on platform
- Tilt alarm with drive & lift cut-out
- All motion audible alarm
- Overload sensing system
- Lowering warning system
- Operator horn
- Hinged railing system (except 4620)
- Half height spring hinged gate
- Lanyard attachment points
- Forklift pockets and tie down/lift lugs

OPTIONS†

- Flashing light
- 1,83 m powered extension deck (except 4632)*
*adds 127 kg to unit weight and capacity remains the same
- Shop airline to platform
- 0.8 kW AC inverter
- 250 Ah batteries
- Hinged railing system (4620 only)
- Full height spring hinged gate

† Capacities, and machine weights may differ when options are added

PROLIFT Access Ltd

☎: 0845 3664755
E: info@proliftaccess.co.uk,
W: www.proliftaccess.co.uk